

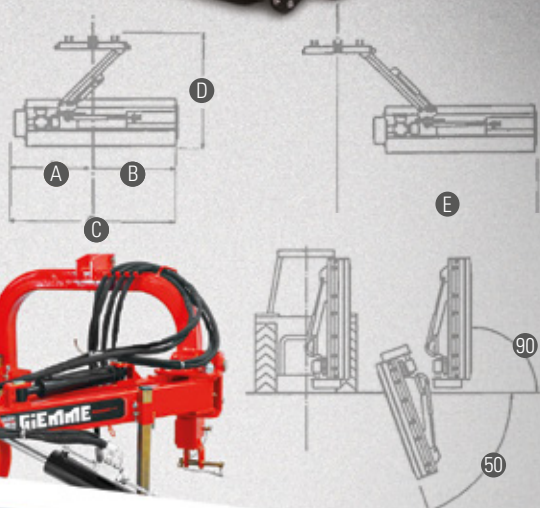

# TRINCIA BCN laterale media

Lateral FLAIL MOWER medium series; BROYEUR d'accotement série moyenne; BÖSCHUNGSMULCHER mittel; TRITURADORA lateral mediana.

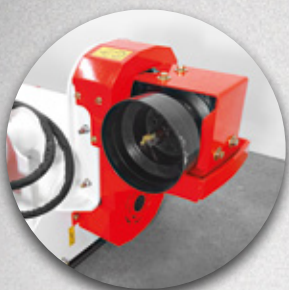

## IT DOTAZIONI STANDARD

! Scatola ingranaggi "COMER" in ghisa con ruota libera 540 giri/min; ! Rotore bilanciato elettronicamente a mazze (Kg 0,800) o coltelli Y; ! Rullo posteriore registrabile con raschiatore; ! Inclinazione idraulica testata trinciante +90°/-50°; ! Sistema meccanico anti collisione; ! Tenditore registrabile; ! Slitte laterali regolabili in altezza; ! Bandelle anteriori di protezione; ! Portellone posteriore apribile; ! Attacco universale a 3 punti cat. I-II; ! Cardano T5 da 1.600 mm.

## EN STANDARD EQUIPMENT

! Cast iron gearbox "COMER" with free wheel 540 rpm; ! Electronically-balanced rotor with hammer blades (Kg 0,800) or Y knife; ! Adjustable rear roller with scraper; ! Hydraulic tilt cutting head +90°/-50°; ! Mechanical shockproof protection system; ! Adjustable tensioner; ! Height adjustable lateral skid; ! Protective cover; ! Opening rear door; ! Universal 3 points linkage cat I-II; ! PTO shaft T5 1.600 mm.

## FR ÉQUIPEMENT STANDARD

! Boîte à engrenages "COMER" en fonte avec roue libre 540 tours/min; ! Rotor balancé électroniquement à marteaux (Kg 0,800) ou couteaux en Y; ! Rouleau postérieur réglable avec grattoir; ! Inclination hydraulique du brayeur +90°/-50°; ! Système mécanique de sécurité anticollision; ! Attelage réglable; ! Patins latéraux réglables en hauteur; ! Bandelles antérieures de protection; ! Portière arrière ouvrable; ! Attelage universel à 3 points cat. I-II; ! Cardan T5 de 1.600 mm.

## DE SERIENAUSSTATTUNG

! Gussgetriebe "COMER" 540 U/min mit Freilauf; ! Elektronisch ausgewuchteter Rotor mit Hammerschlegel (Kg 0,800) oder Y-Messer; ! Höhenverstellbare hintere Walze mit Abstreifer; ! Hydraulische Neigung Mähbalken +90°/-50°; ! Mechanisches Anti-Kollisionssystem; ! Riemenspanner; ! Höhenverstellbare seitliche Gleitkufen; ! Heckklappe öffnenbar; ! Universal-3-Punkt-Aufnahme Kat.I-II; ! Zapfwelle T5 Länge 1.600 mm.

## ES EQUIPO ESTÁNDAR

! Caja de engranajes de arrabio "COMER" con rueda libre 540 rpm; ! Rotor equilibrado electrónicamente con martillos (Kg 0,800) o cuchillas Y; ! Rodillo trasero ajustable con raspador; ! Inclinación hidráulica del cabezal triturador +90°/-50°; ! Sistema mecánico anticollision; ! Tensor ajustable; ! Correderas laterales ajustables en altura; ! Bandas frontales de protección; ! Portón trasero abatible; ! Ataque universal de 3 puntos cat. I-II; ! Cardán T5 1.600 mm.



MODELLO



CODICE



PESO

kg



POTENZA

cv



MASSA TRATTORE

kg



CINGHIE

n°



MAZZE

n°



COLTELLI

n°



SPOSTAMENTO

cm

A B C D E

<b>BCN 140</b>	M1.V5.BCN1	475	50/70	1.600	4	20	40	71	85	156	183	205
<b>BCN 160</b>	M1.V5.BCN2	499	50/70	1.700	4	24	48	71	105	176	183	225
<b>BCN 180</b>	M1.V5.BCN3	530	50/70	1.800	4	28	56	71	125	196	183	245
<b>BCN 140 M</b>	M1.V5.BCN4	475	50/70	1.600	4	20	40	69	115	184	183	235
<b>BCN 160 M</b>	M1.V5.BCN5	499	50/70	1.700	4	24	48	69	135	204	183	255
<b>BCN 180 M</b>	M1.V5.BCN6	530	50/70	1.800	4	28	56	69	155	224	183	275

## BCN-M Scatola ingranaggi esterna

External iron gear box; Boitier à engrenages externe; Getriebegehäuse am Aussenrand; Caja de engranajes externa.